



Workhorse Group Inc. (formerly AMP Electric Vehicles)

Accelerating Electric Drive Medium-Duty & Heavy-Duty Electric Vehicle Technologies



Presented by: Steve Burns, Founder & CEO
May 7, 2015



Background

- 2007 – AMP Electric Vehicles Founded
- March 2013 AMP Electric Vehicles acquired Workhorse Custom Chassis
- April 2015 - AMP Electric Vehicles renamed to Workhorse Group Inc.



Plug-In Electric Market Segments

- Parcel Delivery
- Bakeries
- Uniform / Linen Services
- Utilities - Electric & Gas Utilities
- Snack Food
- Truck Leasing Companies
- U.S. Government



Plug-in Electric Benefits

- **Cost-effective price** (economically attractive without requiring a government voucher or assistance)
- Significantly **reduced fuel expenses**
- Dramatically **reduced maintenance** costs
- **Strengthening Corporate Sustainability** and Social Responsibility Offerings



Powertrain Options

- Plug-in Electric Battery-Powered Options
 - Workhorse **E-GEN™** and E-100 All-Electric

E-GEN features a “right-sized” 60kWh Battery Pack integrated with an EPA-Approved on-board Generator eliminating Range Anxiety

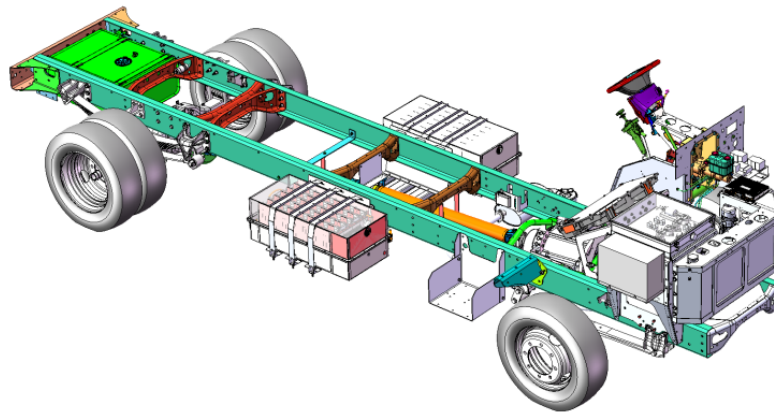

Additional Powertrain Options offered by Workhorse Group

- Gasoline
- Propane
- Compressed Natural Gas



E-GEN Chassis

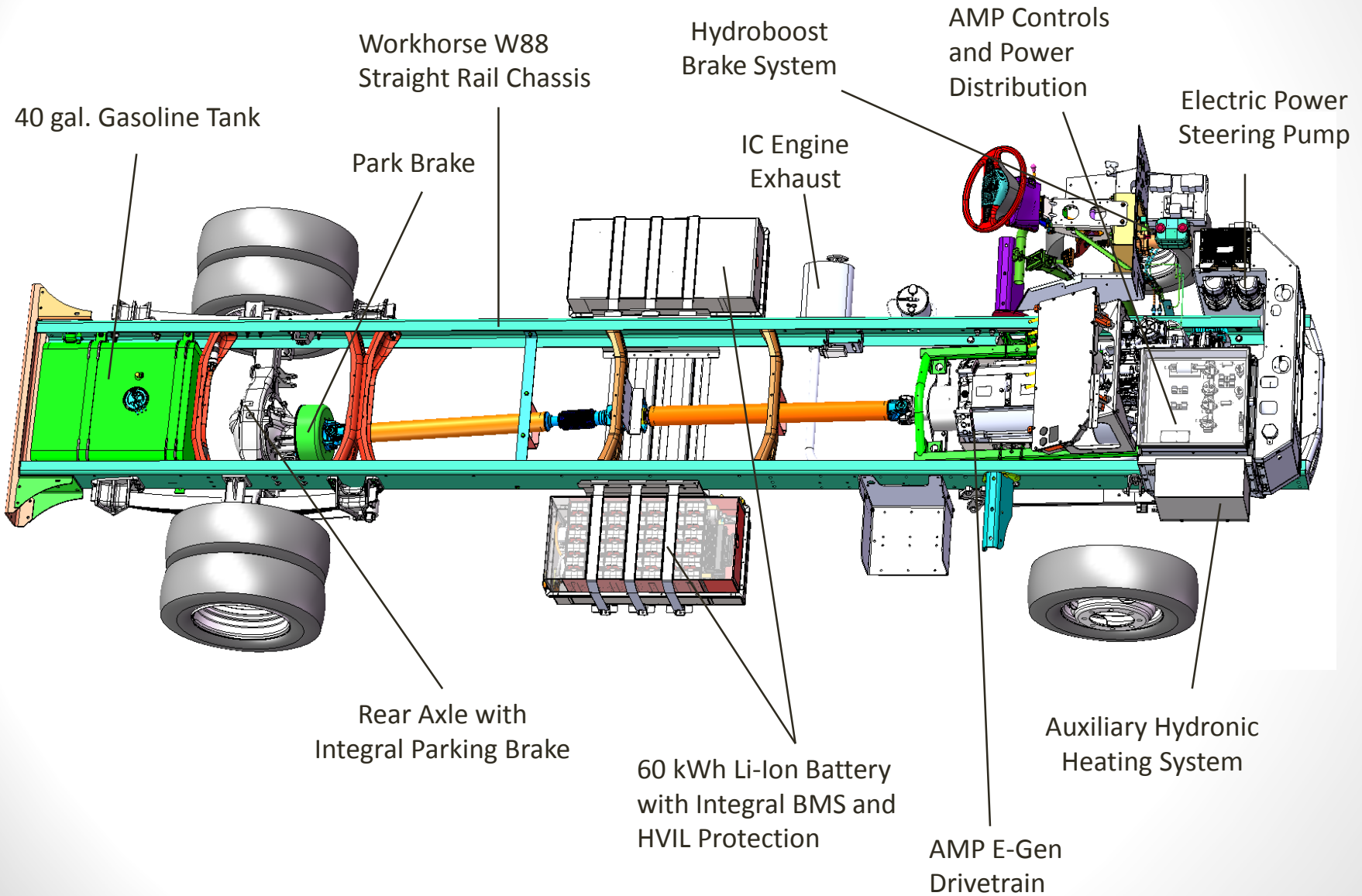

E-GEN Powertrain

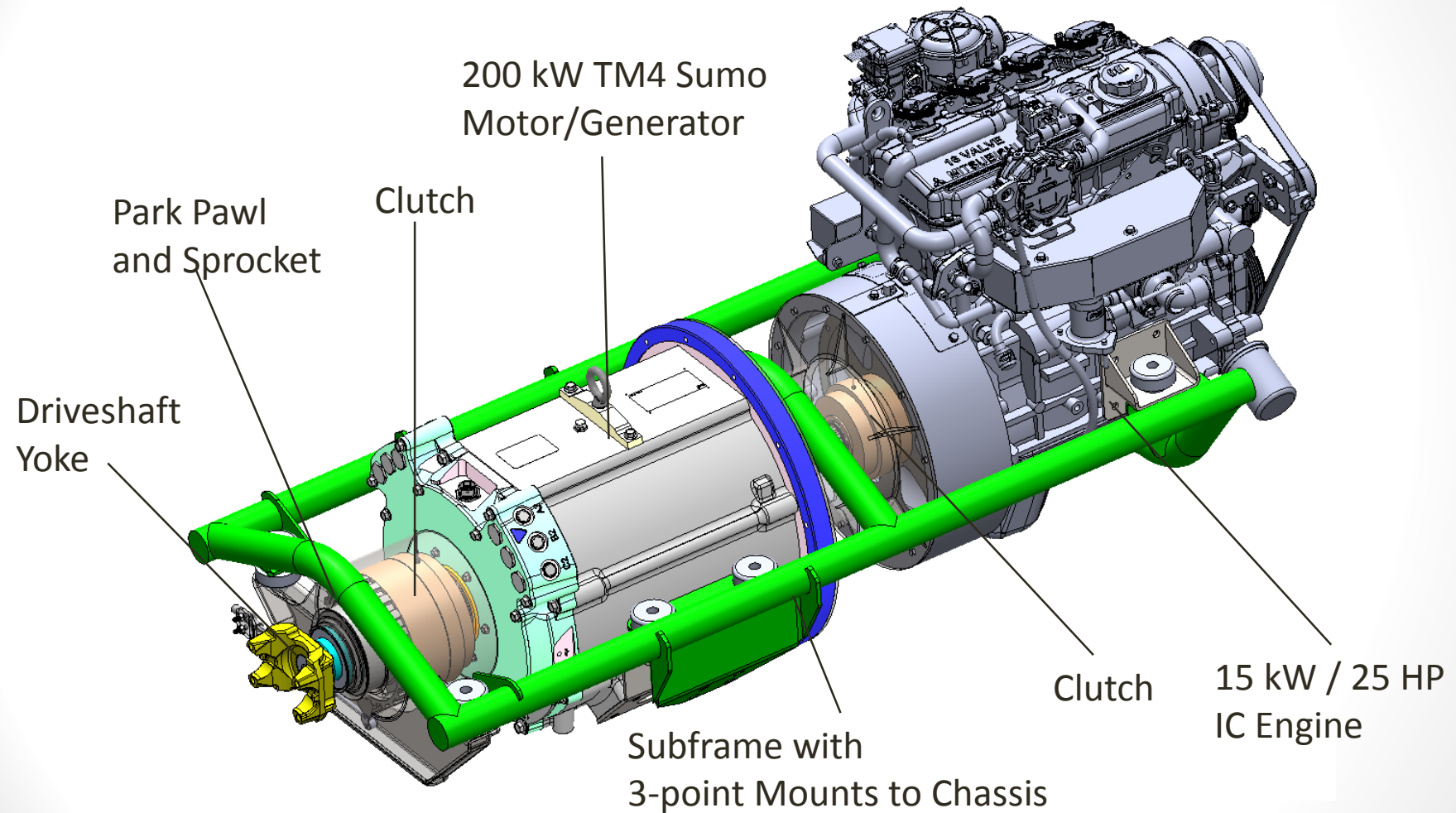

E-GEN Plug-in Charging

- Full charge in approximately 6 hours
- J1772 Level-II compliant on-board charger
- 7 kW maximum power minimizes electrical service infrastructure
- Cold weather charging capable



Features that Deliver the Benefits

Battery Management System

- Depth of Discharge (DOD) - Deep DOD cycles hurt battery life
- BMS manages the charging actions by eliminating over-charging of the battery and not allowing the battery to be discharged completely.

Regenerative Braking

- Conventional vehicles waste energy when braking to stop the vehicle
- Regenerative braking turns the drive motor into a generator when the driver releases his/her foot from the accelerator pedal.
- Deceleration recaptures the energy of a moving vehicle in the form of sending current back into the battery pack.
- Step vans that stop and start hundreds of times a day benefit from regenerative braking

No Transmission

- Direct drive architecture
- Transmissions waste up to 20% of the energy
- Transmissions are significant maintenance items



Features that Deliver the Benefits

On-Board Generator

- E-GENs right-sized battery pack (Panasonic 18650 cells) designed for the average day on the route
- Eliminates range anxiety
- One electro-mechanic device operates as a drive motor or a generator

Dramatically Reduced Emissions

- Zero tailpipe emissions on normal days
- Burn very little gasoline to power the on-board generator on extreme days
- A winning combination for customers, partners communities and our environment

Most efficient step van ever produced by an OEM

- High density, lightweight Panasonic 18650 cells
- Curb weight of the vehicle to 10,800lbs
- Eliminating the energy robbing transmission

Charging Infrastructure

- Reduced charging infrastructure requirements
- Longer range days get the same charge at the depot because E-GEN turns on replenishing electricity



A Glimpse into the Future



- HorseFly™ delivery UAV fully integrated with Workhorse E-GEN
- Delivery costs as low as \$.03/mile
- Charges from Electric Truck
- Increases productivity enabling more deliveries even more efficiently







Workhorse Group Inc. (formerly AMP Electric Vehicles)

Accelerating Electric Drive Medium-Duty & Heavy-Duty Electric Vehicle Technologies



Presented by: Steve Burns, Founder & CEO
May 7, 2015

